



Solid fuel  
boilers

**SOLIDA**



 **sime**®

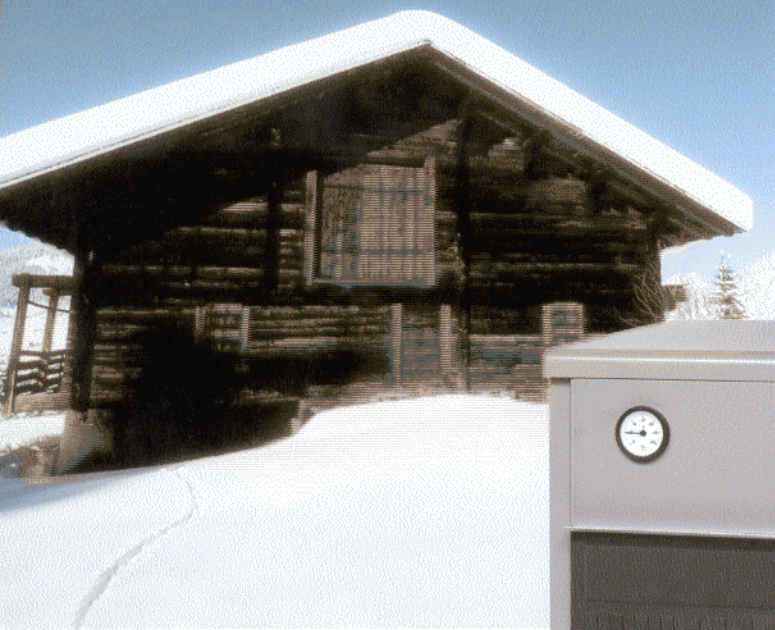

## SOLIDA

### The solution for energy problems

**Solida** has been developed by Sime for central heating only applications and can be fired with wood and coke.

**Solida** boilers can also be modified for oil and gas firing should the need arise.

Sime's research and development team has always given priority to energy efficient appliances and

has recently launched this range of boilers that perfectly meet the new requirements for alternative energy sources. The **Solida** range is available in six models rated from 16.3 up to 39.5 kW and as with all Sime products subjected to the thorough and strict laboratory testing and Quality Assurance process.

## A cast-iron soul

Cast iron is an alloy whose properties remain unaltered throughout time and is synonymous with reliability, long life and ease of maintenance. The particular shape of the cast-iron heat exchanger leads to perfectly balanced combustion with very low gas exhaust emissions. The appliance is complete with a generous insulation of the boiler body, wrapped around with a high-density-glass wool, guarantying complete insulation and low heat loss emission of the **Solida** boilers. The package is completed with a quality, high gloss metal finish enclosure. These are the most remarkable results that have been achieved by Sime through more than thirty years of experience.

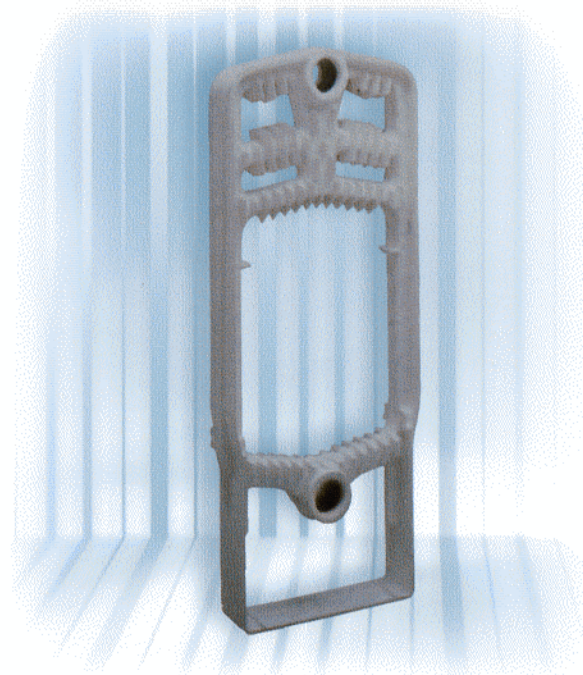
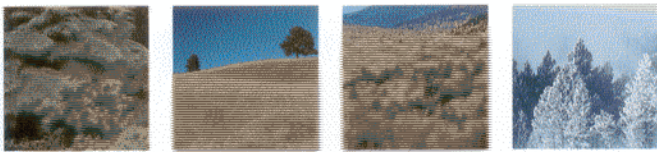

Cast-iron element

## Simplicity and safety

The large loading door makes it easier to load and greater accessibility for cleaning purposes and it is actually possible to get into the combustion chamber and ashtray through the loading door. The smoke outlet is complete with a device to adjust the draft of the boiler. A thermostatic valve adjusts the opening of the door according to the temperature selected, guarantying that the quantity of air required for the combustion is correct at all times. A shaking grate can be supplied upon demand, the purpose of the grate is to let the wood or coke ashes fall down onto the storage accumulator. By activating the shaking grate, the ashes fall down into the accumulator thus ensuring that the floor is clear, allowing the required air to pass through the exchanger and improving the combustion process.

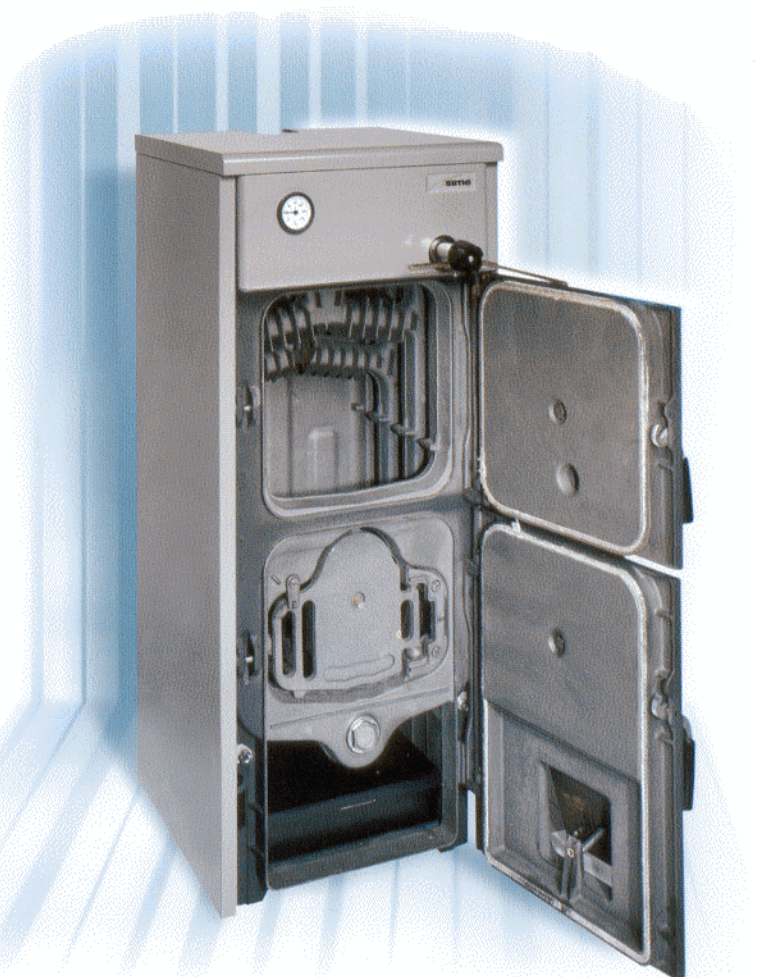

## Technical features

		3	4	5	6	7	8
Heat output (carbon)*	kW	16,3	20,9	25,6	30,2	34,9	39,5
	kcal/h	14.000	18.000	22.000	26.000	30.000	34.000
<b>Carbon operation</b>							
Load duration	h	2	2	2	2	2	2
Load volume	dm <sup>3</sup>	17,0	25,5	34,0	42,5	51,0	59,5
Minimum chimney depression	mbar	0,08	0,10	0,12	0,13	0,15	0,18
<b>Dimensions</b>							
P (depth)	mm	355	455	555	655	755	855
L (combustion chamber depth)	mm	190	290	390	490	590	690
Cast-iron sections	n°	3	4	5	6	7	8
Max. working pressure	bar	4	4	4	4	4	4
Test pressure	bar	6	6	6	6	6	6
Boiler capacity	l	23	27	31	35	39	43
Water head losses ( $\Delta t$ 10°C)	mbar	12	17	26	29	34	40
Weight	kg	190	225	270	310	345	385

\* The heat rate will be reduced with about 10% for the operation with hard wood (birch - oak - olive).

## Dimensions - Hydraulic connections

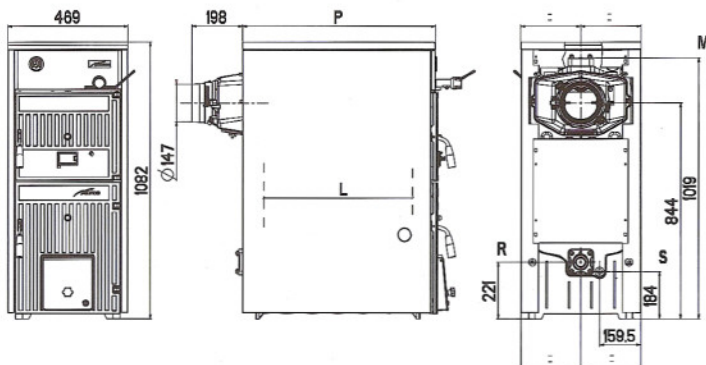

### Connections

M	C.H. flow	2"
R	C.H. return	2"
S	Boiler drain	1/2"

Fonderie SIME S.p.A. reserves the right to modify its products at any time and without prior notification with the intention of improving them without impairing their basic characteristics. This brochure may not, therefore, be considered a contract with third parties.



### Hydronic Systems (Australia) Pty Ltd

P O Box 294 Braeside VIC 3195 ABN 50 354 796 935

showroom 11 Fiveways Boulevard Keysborough VIC 3173

phone 1300 00 1800 fax (+613) 9798 5133

email enquires@huntheat.com.au website www.huntheat.com.au